

- NOTES:
- 1) Tolerances unless stated:
Linear: $\pm 0.1\text{mm}$,
Angular: $\pm 0.25^\circ$
 - 2) Remove all burrs
 - 3) Do not scale
 - 4) Surface texture $\sqrt{1.6}$

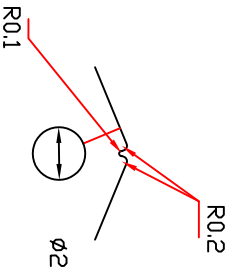
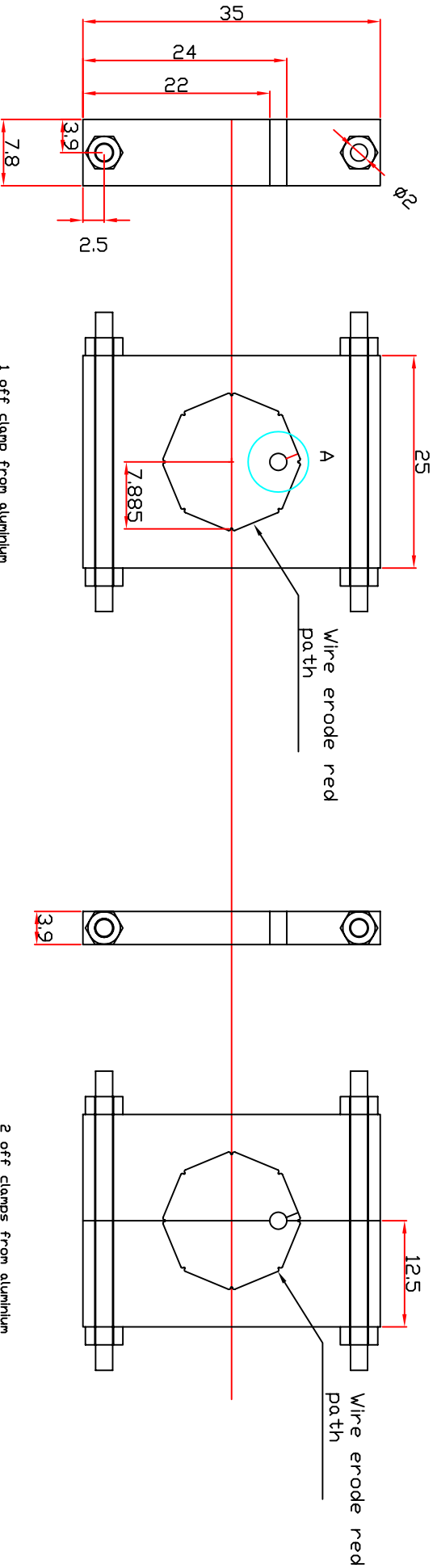

A (10: 1)

THIRD ANGLE
PROJECTION
DRAWING
PREPARED IN
ACCORDANCE
TO BS308

GENERAL SURFACE FINISH: $\mu\text{m CLA R}_a$ UNLESS OTHERWISE STATED
HEAT & SURFACE TREATMENT
DIMENSIONS: mm
MATERIAL: Aluminium - 5083
TITLE: Wire erode of magnet assembly tooling

ISSUE	DATE	INITIAL	ISSUE	CHK	APP.
1	21/01/08			MM	
2					
3					
4					
5					
6					
7					

UNIVERSITY OF SHEFFIELD
DEPARTMENT OF PHYSICS & ASTRONOMY
SHEFFIELD
S3 7RH
Tel: 0114-2223543

SCALE: 4 : 1
DATE: 21/01/08

DRAWN: M. MOHAMMAD
RAL REF: TD-SU-18

A4